



Product Name: Magstripe Card Reader
with LCD Display

Product Type: MR-90C

Features:

Use ISO ABA Track II magnetic stripe reader and card---MR-90C

Standalone or PC on line through JAS software.

With backlit keypad & LCD.

Programmable door delay close time from 0~255 seconds, when door unlock over delay time setting, the alarm will output.

Support 10000 users when PR-90C under standalone situation.

Can be used by 0.18cm,0.76cm EM card or Key tag.

Built-in clock and calendar.

Built-in RS232 & RS485 interface.

PR-90C can save 10000 history record.

Reader ID can be setting through Dip switch.

Built-in Watch Dog, the system never hang .

Built-in tamper switch detects when case is forced open or destroy, the alarm signal output (A. B. point).

Data is protected even after power failure .

Inside door can be installed a push button for outdoor access control.

With real-time printing function (RS232 port), can be connected to a serial printer.

Operation mode: Card Only, Card + PIN, PIN or card, Facility Code only Opening, or inhibit Access.

Intranet network with TCP/IP Converter (option device).

Two different housing as the picture for choice.

Configuration :

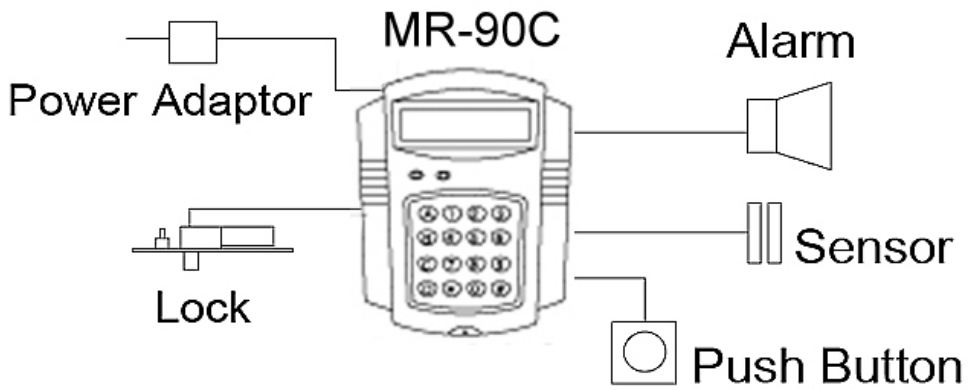

Specifications:

LCD	2X16 Characters (backlit LCD)
Keypad	4X4, 16keys
Power requirement	DC 12V 1Amp
Operating temperature	32 ° F~122 ° F(0 ° C~50 ° C)
Humidity	20%~90%RH
Dimensions	160(L) X 185(W) X48(H) mm
Relay	3 relay contact (Max. DC 12V 1Amp)

Ordering Information:

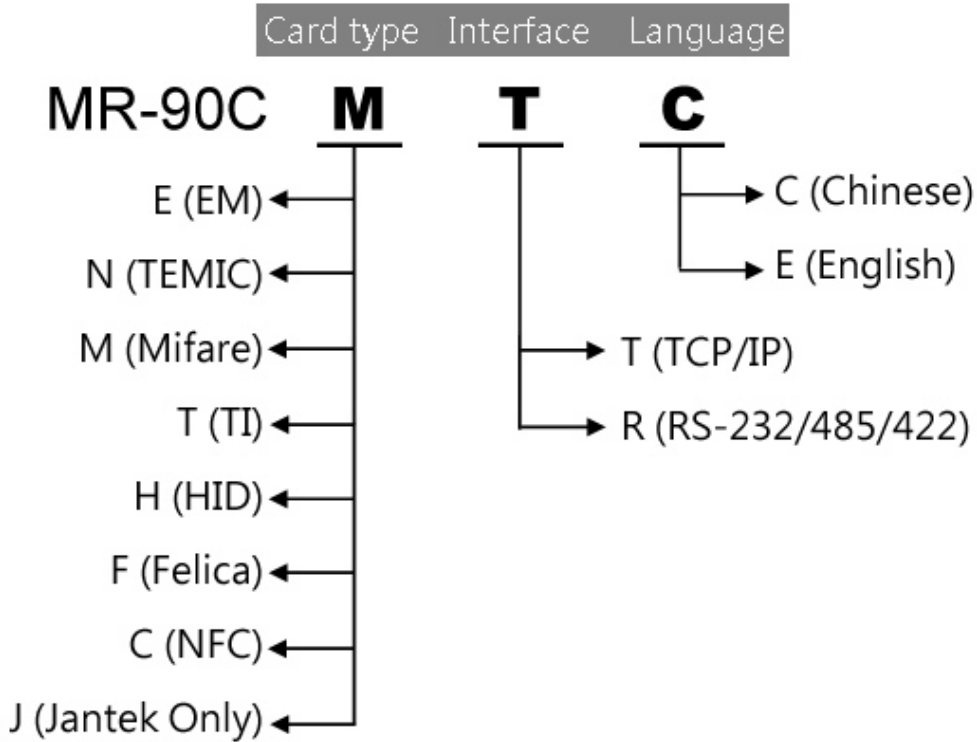

Reference models:

Taiwan Jantek Electronics., Ltd.
 Add:6F-1, No. 1, Wuquan 1St.Rd.,Xinzhuang District, TEL : 886-2-22991255
 New Taipei City 24892,Taiwan, R.O.C.
 FAX : 02-2299-1257 / 02-2299-7412

www.jantek.com.tw
 Email : service@jantek.com.tw